



# Keysight TC285P

## 5 – 30 GHz Frequency Doubler

HMMC-5630-BLK (Waffle Pack)

HMMC-5630-TR1 (Tape & Reel)

Data Sheet

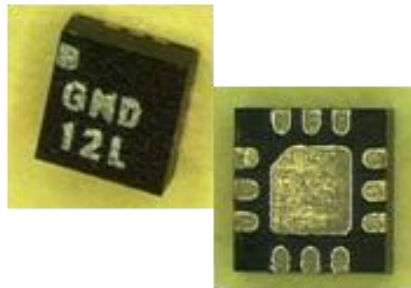

### Features

- **Doubled Bandwidth: 5– 30 GHz**
- **Pass-Thru Bandwidth: DC to 20 GHz**
- **Input Power: -10 to 0 dBm**
- **Output Power: 0 dBm typical**
- **Selectable Pass-Thru and Doubler modes**
- **Output Power Adjustment**
- **Vsupply = -3V**
- **RoHS Compatible**

### Chip and Package Geometries

Attribute	Dimension
Package Type Package	12-lead quad flat no-lead (QFN) plastic with heat sink
Size	2 × 2 mm (79 × 79 mils)
Package Thickness	0.90 mm (23 mils)
Package Leads	0.25 × 0.50 mm (10 × 20 mils) width × pitch

### Description

The TC285 is an active frequency doubler fabricated in HFTC's InP heterojunction bipolar transistor (HBT) process. Pass-thru mode and Doubler mode are selectable. Doubled frequency output bandwidth is from 5 to 30 GHz. Pass-thru mode bandwidth is from DC to 20 GHz. Input and Output can be differential or single-ended. Output power is adjustable. The circuit is primarily digital and the output at low frequencies is a square wave.

### Absolute Maximum Ratings <sup>[1]</sup>

Symbol	Parameters/Conditions	Min	Max	Units
Pin	CW Input power (single ended)		3	dBm
Vin	Peak Input voltage (75 Ohm input)	-1.0	0.45	V
VEE	Emitter voltage	-3.5	-2.8	V
ITUNE1	Always grounded	0	0	V
ITUNE2	Output power control	-5	0	V
VFREQMODE	Pass-Thru mode select	-0.3	0.3	V
	Doubler mode select	2	3.5	V
VON_OFF	Full bias select	-3.5	-2	V
	Power down (pass-thru mode only)	0	2	V
	Power down (pass-thru mode only)	0.5	1.5	mA
T <sub>j</sub>	Maximum Junction Temperature <sup>[2]</sup>		150	°C
T <sub>A</sub> <sup>[2]</sup>	Ambient Temperature	-55	75	°C
T <sub>stg</sub>	Storage Temperature	-65	165	°C
T <sub>max</sub> <sup>[3]</sup>	Maximum Assembly Temperature		260	°C

### Notes:

<sup>[1]</sup> Operation in excess of any one of these conditions may result in permanent damage to this device. T<sub>A</sub> = 25 °C except for T<sub>ch</sub>, T<sub>stg</sub>, and T<sub>max</sub>.

<sup>[2]</sup> MTTF > 5 × 10<sup>5</sup> hr. Operation in excess of T<sub>A</sub> will degrade MTTF.

<sup>[3]</sup> Refer to JEDEC J-STD-020D for detailed reflow profile, 3 reflows max.

## DC Specifications / Physical Properties<sup>[1]</sup>

Symbol	Parameters/Condition	Min	Typ	Max	Units
Vee	Emitter voltage		-3		V
lee	Emitter current	-100	-84	-65	mA
lee_LOW	Emitter current at ITUNE2=-4V		-50		mA
lee_OFF	Emitter current at VON_OFF=0V	-10	-4		mA

### Notes:

<sup>[1]</sup> Measured on wafer with  $T_{\text{chuck}} = 25\text{ }^{\circ}\text{C}$  unless otherwise noted

## RF Specifications<sup>[1]</sup>

Symbol	Parameters/Condition	Min	Typ	Max	Units
P1_10_10	Pout@10 GHz/ Pass-thru mode, Pin @ 10GHz	-3	1.2		dBm
P1_10_20	Pout@20 GHz/ Pass-thru mode, Pin @ 10GHz		-21	-15	dBc
P1_15_15	Pout@15 GHz/ Pass-thru mode, Pin @ 15GHz	-3	1.7		dBm
P1_15_30	Pout@30 GHz/ Pass-thru mode, Pin @ 15GHz		-18	-12	dBc
P1_20_20	Pout@20 GHz/ Pass-thru mode, Pin @ 20GHz	-4	0		dBm
P1_20_40	Pout@40 GHz/ Pass-thru mode, Pin @ 20GHz		-14	-10	dBc
P2_7_7	Pout@7 GHz/ Doubler mode, Pin @ 7GHz		-33	-18	dBc
P2_7_14	Pout@14 GHz/ Doubler mode, Pin @ 7GHz	-3	1.5		dBm
P2_10_10	Pout@10 GHz/ Doubler mode, Pin @ 10GHz		-30	-20	dBc
P2_10_20	Pout@20 GHz/ Doubler mode, Pin @ 10GHz	-3	1		dBm
P2_135_135	Pout@13.5 GHz/ Doubler mode, Pin @ 13.5GHz		-24	-15	dBc
P2_135_27	Pout@27 GHz/ Doubler mode, Pin @ 13.5GHz	-4	0		dBm
S11_10	S11 at 10 GHz, Single-ended input IN			-8	dB
S11_20	S11 at 20 GHz, Single-ended input IN			-8	dB
S11_27	S11 at 27 GHz, Single-ended input IN			-6	dB
S22_10	S22 at 10 GHz, Single-ended output OUT			-15	dB
S22_20	S22 at 20 GHz, Single-ended output OUT			-8	dB
S22_27	S22 at 27 GHz, Single-ended output OUT			-8	dB
Phase Noise	SSB phase noise at 5 MHz offset, pass-thru mode, Output Frequency=6 GHz		-146		dBc/Hz
Phase Noise	SSB phase noise at 5 MHz offset, doubler-mode, Output frequency=12 GHz		-139		dBc/Hz

### Notes:

<sup>[1]</sup> Measured on wafer with  $T_{\text{chuck}} = 25\text{ }^{\circ}\text{C}$  unless otherwise noted. VEE=-3V, VON\_OFF=-3V, ITUNE2=0V, VFREQMODE=0V or 3.3V, Pin=-10dBm

## ESD Limits [1]

Pad	Condition	ESD	Units
ITUNE1	Unbiased	1500	V
ITUNE2	Unbiased	1500	V
VON_OFF	Unbiased	2000	V
VFREQMODE	Unbiased	1500	V
VEE	Unbiased	1500	V
IN and nIN	Unbiased	200	V
OUT and nOUT	Unbiased	500	V

### Notes:

[1] Human Body Model: 100 pF, 1.5 kOhms

## Operation

The TC285 is an active doubler using InP heterojunction bipolar transistors. It is essentially a digital circuit and the output at low frequencies approximates a square wave. In the doubler mode the even harmonics of the doubled output and the signal at the input frequency (sub-harmonic) are suppressed. In the pass-thru mode the even harmonics are suppressed. The TC285 is switchable from pass-thru mode to doubler mode (VFREQMODE control line) and the output power is adjustable (ITUNE2 control line). With no input power the TC285 will self-oscillate at a low level at about 10 GHz in the doubler mode. To suppress this oscillation select pass-thru mode.

## Biasing and In/Out Impedance

The input and output can be single-ended or differential. Input and output can be DC coupled or AC coupled through external capacitors. If the input is DC coupled, both inputs must have the same DC resistance to ground. The input impedance for IN and nIN is 75 Ohms. The output impedance for OUT and nOUT is 50 Ohms.

Nominal biases and order for biasing up (ITUNE1 is always grounded):

1. VEE                    -3V  
    Alternate VEE       -3.5                    through external 5 Ohm resistor
2. VON\_OFF              -3V                      normal full bias condition
3. VFREQMODE            0V                        pass-thru mode
4. ITUNE2                0 to -5V                output power control, 0V is full power

After the chip is biased up, the doubler mode can be selected with 2 to 3.5V on the VFREQMODE select line. When in the pass-thru mode, the power-down state can be implemented by applying 0 to 2V to the VON\_OFF select line.

Biasing down is in reverse order.

## Assembly Techniques

Surface-mount bypass capacitors (0.01- $\mu$ F monoblock or similar to ground) should be placed as close as possible to the dc bias leads  $V_{EE}$ . This package is compatible with wave-solder or reflow printed circuit board soldering processes. The backside heat slug must be soldered to a thermal heatsink that forms dc and RF ground for the circuit. Poor heatsink conductivity may cause  $T_{BS}$  to exceed  $+75^{\circ}\text{C}$  and degrade the reliability of the circuit.

GaAs MMICs are ESD sensitive. ESD preventive measures must be employed in all aspects of storage, handling and assembly. MMIC ESD precautions, handling considerations, and die attach and bonding methods are critical factors in successful GaAs MMIC performance and reliability. Please refer to Keysight application note #54, "GaAs MMIC ESD, Die Attach and Bonding Guidelines" for additional information on these subjects.

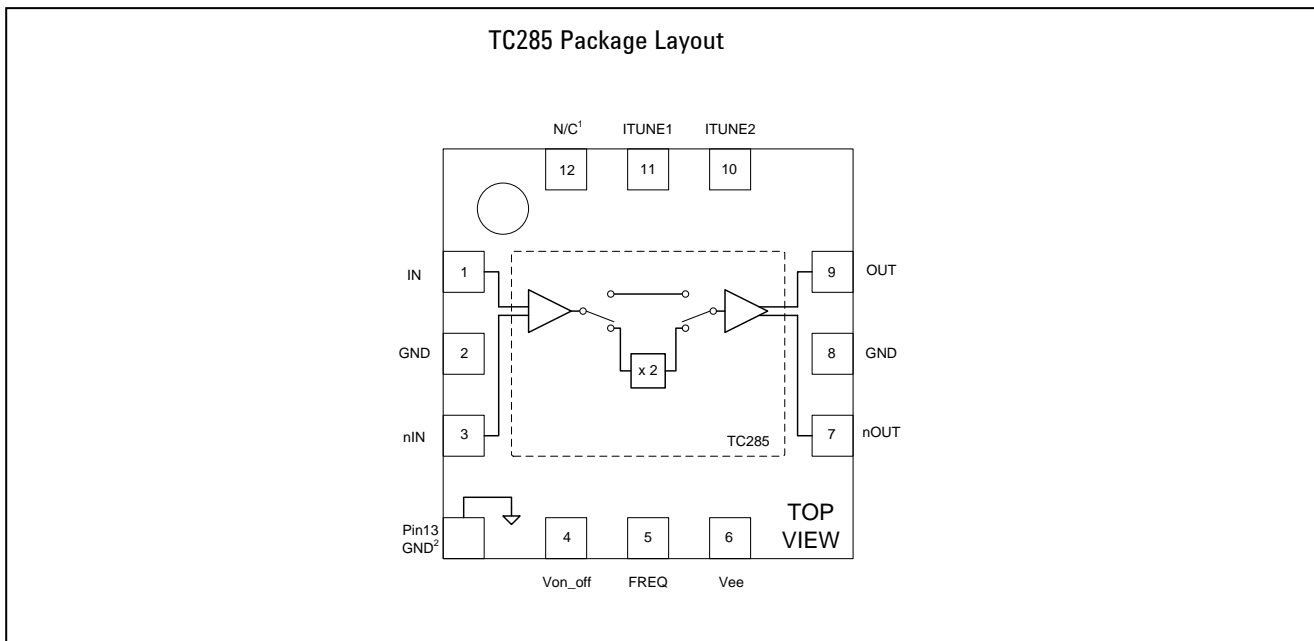
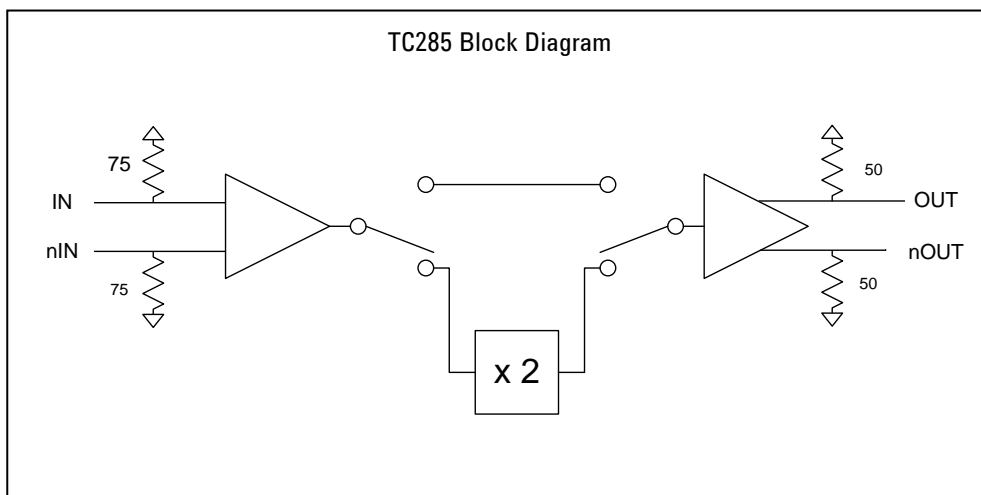

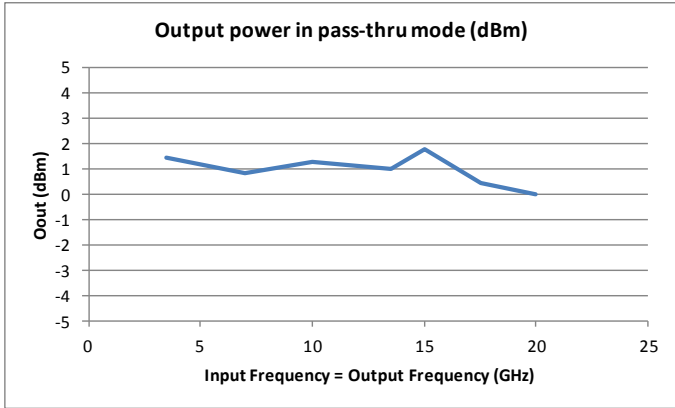

Typical output power in pass-thru mode vs frequency. Measured on wafer with Pin=-10 dBm, ITUNE2=0V, VFREQMODE=0V

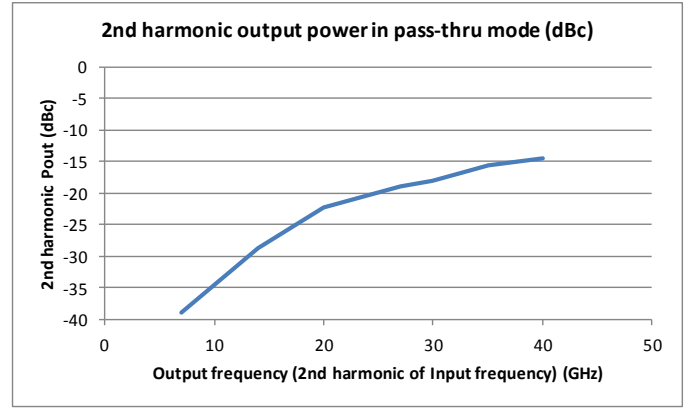

Typical 2<sup>nd</sup> harmonic output power in pass-thru mode vs 2<sup>nd</sup> harmonic frequency. Measured on wafer with Pin=-10dBm, ITUNE2=0, VFREQMODE=0V

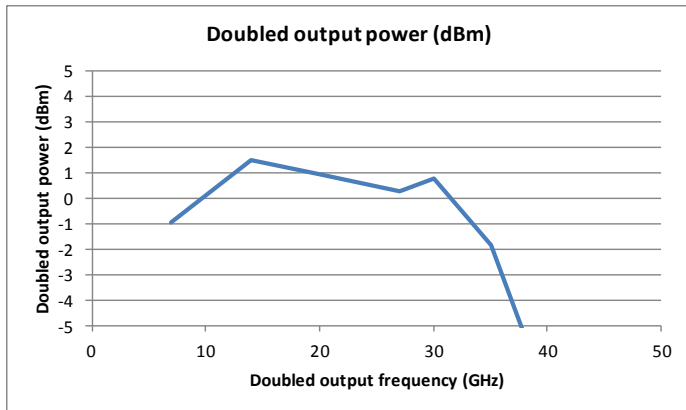

Typical doubled output power in doubler mode vs doubled frequency. Measured on wafer with Pin=-10dBm, ITUNE2=0V, VFREQMODE=3.3V.

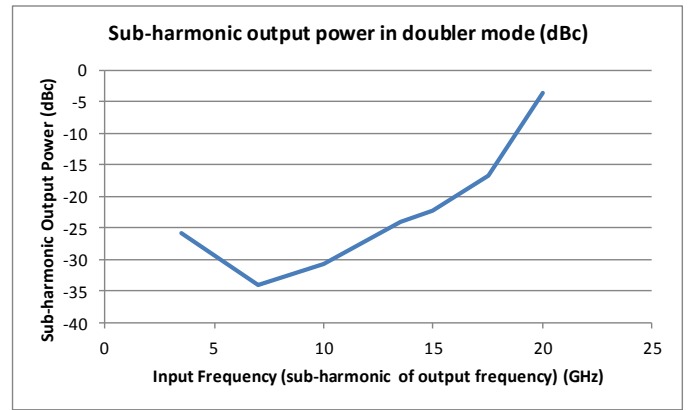

Typical sub-harmonic output power in doubler mode vs input frequency. Measured on wafer with Pin=-10dBm, ITUNE2=0V, VFREQMODE=3.3V.

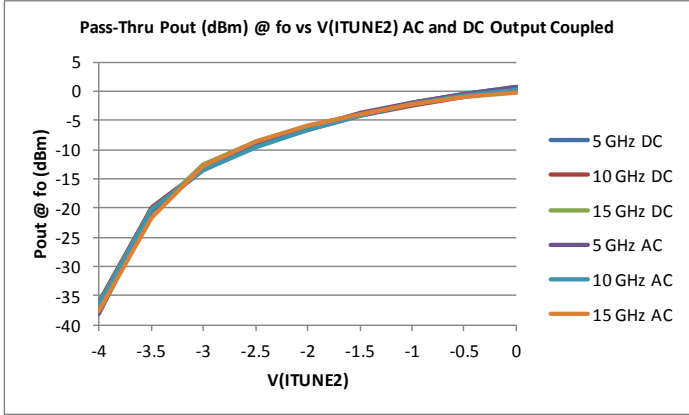

Typical output power in pass-thru mode vs ITUNE2 voltage. Measured in modular breadboard package. Pin=-10dBm.

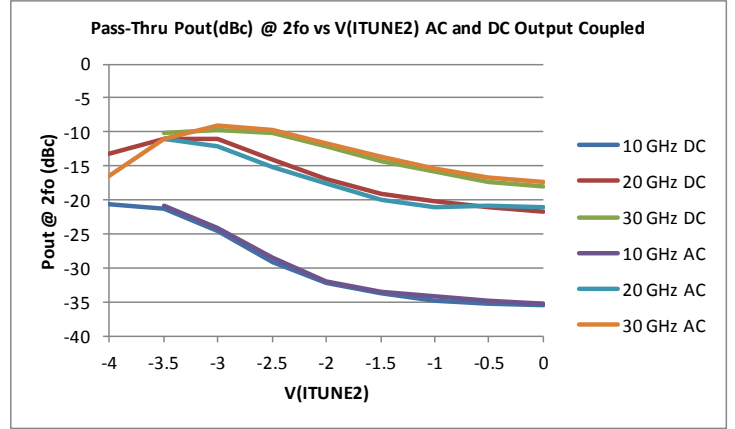

Typical 2<sup>nd</sup> harmonic of output power in pass-thru mode vs ITUNE2 voltage. Measured in modular breadboard package. Pin=-10dBm.

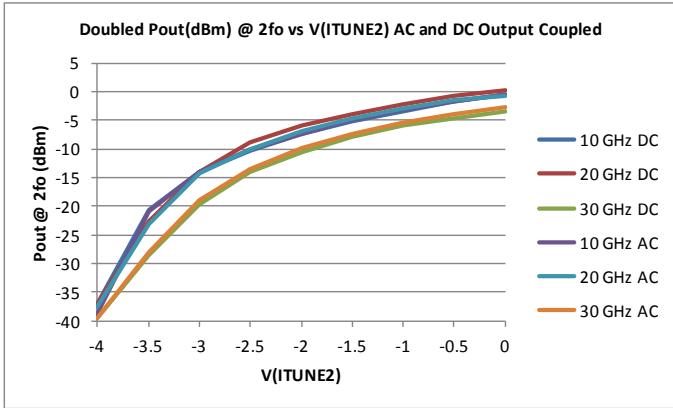

Typical output power in doubler mode vs ITUNE2 voltage. Measured in modular breadboard package. Pin=-10dBm.

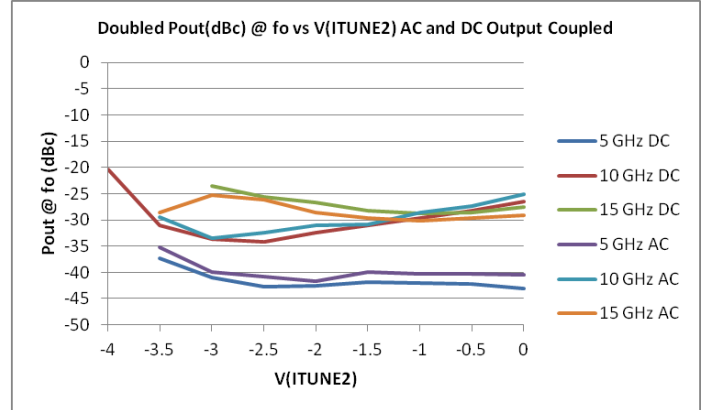

Typical sub-harmonic output power in doubler mode vs ITUNE2 voltage. Measured in modular breadboard package. Pin=-10dBm.

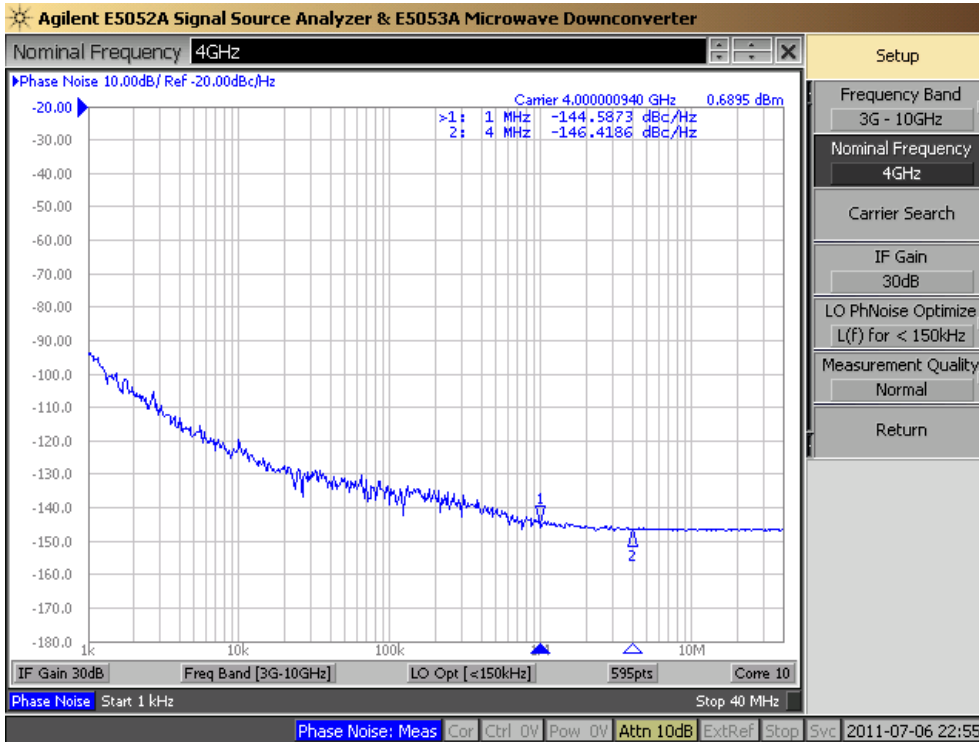

Typical phase noise in pass-thru mode at 4 GHz. Measured in modular breadboard package.

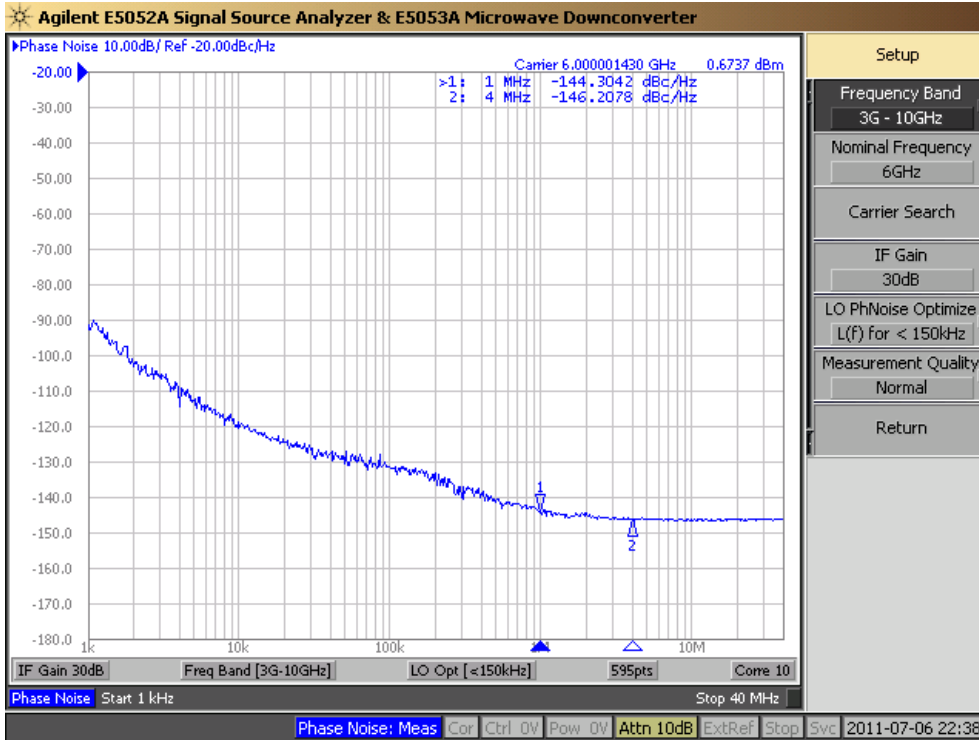

Typical phase noise in pass-thru mode at 6 GHz. Measured in modular breadboard package.

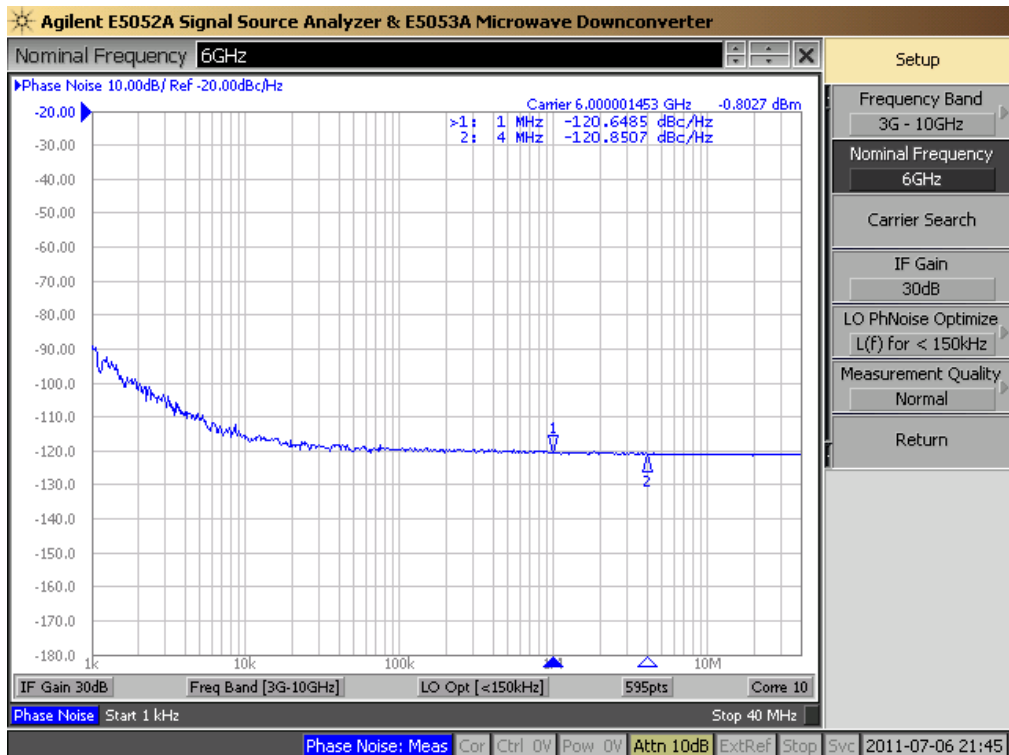

Phase noise in doubler mode at 6 GHz doubled output. Measured in modular breadboard package.

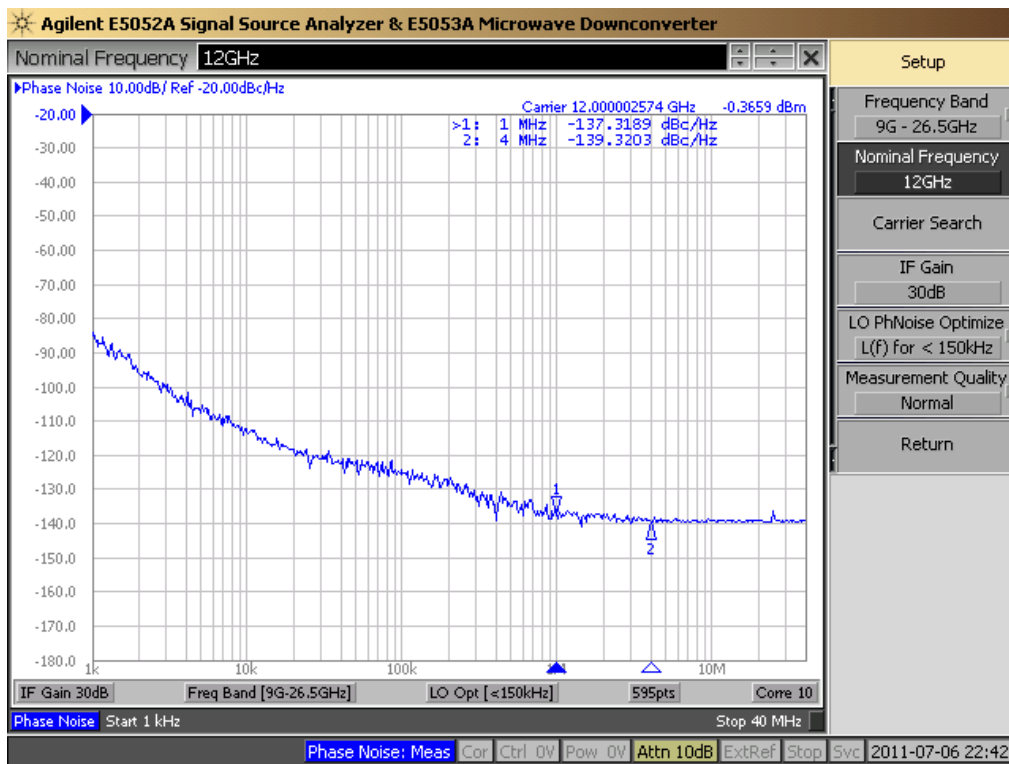

Phase noise in doubler mode at 12 GHz doubled output. Measured in modular breadboard package.

## TC283P Package Dimensions

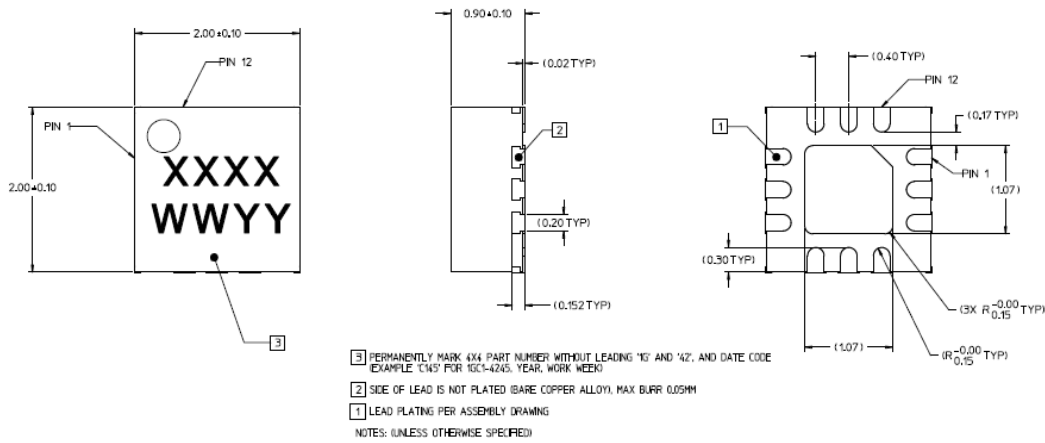

## TC283P Tape and Reel Information

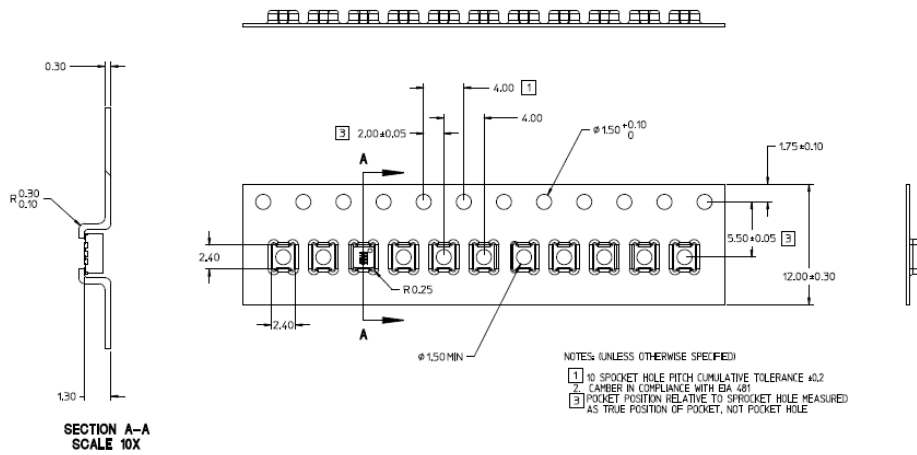

This data sheet contains a variety of typical and guaranteed performance data. This information supplied should not be interpreted as a complete list of circuit specifications. In this data sheet, the term *typical* refers to the 50<sup>th</sup> percentile performance. For additional information contact WPTC Marketing at 1-577-4211.